

Technology that saves lives

Intelligent Smoke Detector

KIR-PD

ROTARY
Compatible with FX Series control panels
ADDRESSING

Overview

The KIR-PD optical smoke detector brings advanced sensing technology to a practical design that increases efficiency, saves installation time, cuts costs, and extends life safety and property protection capabilities. Continuous self-diagnostics ensure reliability over the long-haul, while environmental compensation helps reduce maintenance costs.

Like all KIR Series detectors, the KIR-PD is an intelligent device that gathers analog information from its optical sensor, converting this data into digital signals. To make an alarm decision, the detector's on-board microprocessor measures and analyzes sensor readings and compares this information to historical data. Digital filters remove signal patterns that are not typical of fires, thus virtually eliminating unwanted alarms.

Standard Features

Note: Some features described here may not be supported by all control systems. Check your control panel's *Installation and Operation Guide* for details.

- Next Generation Optical Smoke Sensing Technology
- Wide 0.53 to 3.94 %/ft. (1.7 to 12.35 %/m) smoke obscuration
- Uses Existing Wiring
- Up To 250 Total Addresses Per Loop
- Two Levels of Environmental Compensation
- Two Levels of Dirty Detector Warning
- Five Sensitivity Settings
- Non-Volatile Memory
- Rotary Addressing
- Identification of Dirty or Defective Detectors
- Automatic Day/Night Sensitivity Adjustment
- Bicolor (Green/Red) Status Led
- Standard, Relay, Fault Isolator, and Audible Mounting Bases
- Sensor Markings Provide Easy Testing Identification

Application

The KIR-PD detects extremely small particles of combustion and triggers an alarm at the first sign of smoke. Thanks to its high-performance forward-scattering reflective response technology, the photoelectric smoke sensor responds quickly and reliably to a wide range of fire types, especially slow burning fires fuelled by combustibles typically found in modern multi-use buildings.

Compatibility

The KIR-PD is compatible with FX Series intelligent panels.

Installation

KIR Series detector bases mount to North American 1-gang boxes, 3-1/2 inch or 4 inch octagon boxes, and to 4 inch square electrical boxes 1-1/2 inches (38 mm) deep. They mount to European BESA and 1-gang boxes with 60.3 mm fixing centers. See mounting base installation and wiring for more information.

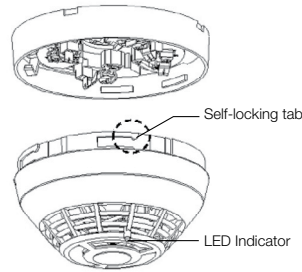

Sensing and reporting technology

The microprocessor in each detector provides additional benefits - Self-diagnostics and History Log, and Fast, Stable Communication.

Self-diagnostics and History Log - Each KIR Series detector constantly runs self-checks to provide important maintenance information. The results of the self-check are automatically updated and permanently stored in the detector's non-volatile memory

Fast Stable Communication - On-board intelligence means less information needs to be sent between the detector and the loop controller. Other than regular supervisory polling response, the detector only needs to communicate with the loop controller when it has something new to report.

Testing & Maintenance

Each detector automatically identifies when it is dirty or defective and causes a "dirty detector" message. The detector's sensitivity measurement can also be transmitted to the loop controller. A sensitivity report may be printed to satisfy NFPA sensitivity measurements, which must be conducted at the end of the first year and every two years thereafter.

The user-friendly maintenance program shows the current state of each detector and other pertinent messages. Single detectors may be turned off temporarily from the control panel. Availability of maintenance features is dependent on the fire alarm system used.

Accessories

Detector mounting bases have wiring terminals that are accessible from the "room-side" after mounting the base to the electrical box. The bases mount to North American 1-gang boxes and to 3½ inch or 4 inch octagon boxes, 1½ inches (38 mm) deep. They also mount to European BESA and 1-gang boxes with 60.3 mm fixing centers. The KI-SB4, KI-RB4, and KI-IB4 mount to North American 4 inch sq. electrical boxes in addition to the above boxes. They include the GSA-TS4 Trim Skirt, which is used to cover the "mounting ears" on the base. The KI-ABST mounts to a 4 inch square box only.

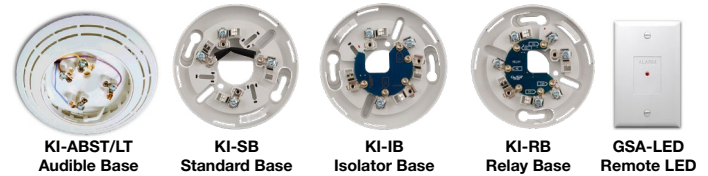

Remote LED - The remote LED connects to the KI-SB or KI-SB4 Standard Base only. It features a North American size 1-gang plastic faceplate with a white finish and red alarm LED.

Trim Skirt - Supplied with 4 inch bases, it can also be ordered separately to use with the other bases to help hide surface imperfections not covered by the smaller bases.

Sounder Bases - KIR Series sounder bases are designed for use where localized or group alarm signaling is required.

- **KI-ABST** bases provide sounder capability to KIR Series heat and smoke detectors.
- **KI-ABLT** bases provide 520 Hz low frequency sounder capability to KIR Series smoke and heat detectors. The KI-ABLT is suitable for applications requiring low frequency audible tones.

Device Addressing

Programming is made easy through the rotary dials located on the back of the detector head. Use a screwdriver to adjust the TENS rotary switch (0 through 12) to set the 10s digit and the ONES rotary switch to set the digit 0 through 9. The control panel will identify any duplicate addresses.

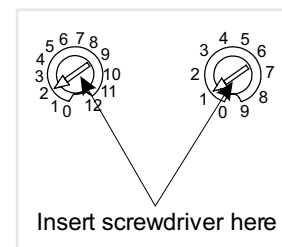

Example: device address 21, set TENS rotary switch to 2 and set the ONES rotary switch to 1.

Typical Wiring

The detector mounting bases accept #18 AWG (0.75mm²), #16 (1.0mm²), #14 AWG (1.5mm²), and #12 AWG (2.5mm²) wire sizes. Sizes #16 AWG (1.0mm²) and #18 AWG (0.75mm²) are preferred for ease of installation.

Standard Detector Base, KI-SB, KI-SB4

This is the basic mounting base for Kidde KIR Series detectors. The GSA-LED Remote LED is supported by this Base.

Term	Description
1	Not Used
2	DATA IN/OUT (+)
3	Not Used
4	DATA IN (-)
4	Remote LED (+)
5	Remote LED (+)
6	Not Used
7	DATA OUT (-)

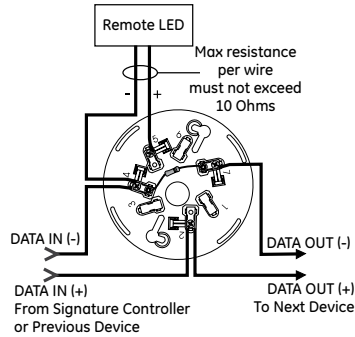

Isolator Detector Base, KI-IB, KI-IB4

This base includes a built-in line fault isolator for use on Class A circuits. A detector must be installed for it to operate. The isolator base does not support the GSA-LED Remote LED.

The isolator operates as follows:

- a short on the line causes all isolators to open within 23 msec
- at 10 msec intervals, beginning on one side of the Class A circuit nearest the loop controller, the isolators close to provide the next isolator down the line with power
- when the isolator next to the short closes, it reopens within 10 msec.

The process repeats beginning on the other side of the loop controller.

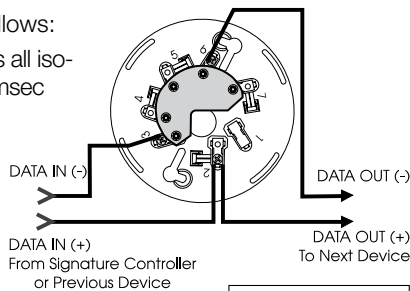

Term	Description
1	Not Used
2	DATA IN/OUT (+)
3	DATA IN (-)
4	Not Used
5	Not Used
6	DATA OUT (-)
7	Not Used

Relay Detector Base, KI-RB, KI-RB4

This base includes a relay. Normally Open or Normally Closed operation is selected during installation. The dry contact is rated for 1 amp (pilot duty) @ 30 Vdc. The relay's position is supervised to avoid accidentally jarring it out of position. The KI-RB can be operated as a control relay if programmed to do so at the control panel. The relay base does not support the GSA-LED Remote LED.

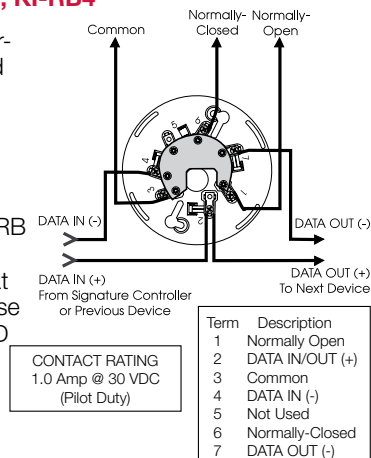

Term	Description
1	Normally Open
2	DATA IN/OUT (+)
3	Common
4	DATA IN (-)
5	Not Used
6	Normally-Closed
7	DATA OUT (-)

Audible Sounder Bases, Fire Mode

AB4G, AB4G-LF sounder bases

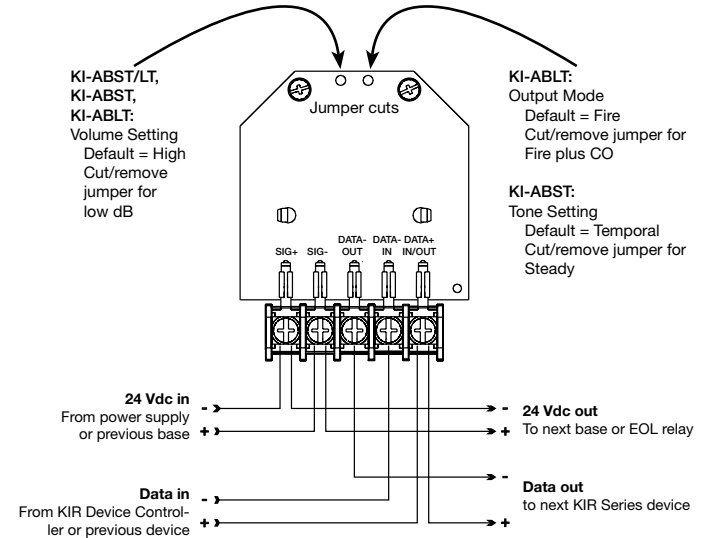

Warnings & Cautions

- This detector does not operate without electrical power. As fires frequently cause power interruption, discuss further safeguards with the local fire protection specialist.
- This detector does not sense fires in areas where smoke cannot reach the detector. Smoke from fires in walls, roofs, or on the opposite side of closed doors may not reach the detector.
- Photoelectric detectors have a wide range of fire-sensing capabilities and are best suited for detecting slow, smoldering fires.
- In Canada, install according to CAN/ULC-S524 Standard for the Installation of Fire Alarm Systems, CSA C22.1 Canadian Electrical Code, and the local authority having jurisdiction.



Technology that saves lives

Contact us

Phone: 888.244.9979 (Option 4)
 Email: kidde.fire@carrier.com
 Website: kidde-esfire.com

Kidde is a Carrier brand.
 8985 Town Center Pkwy,
 Bradenton, FL 34202

© 2020 Carrier
 All rights reserved.

Dimensions

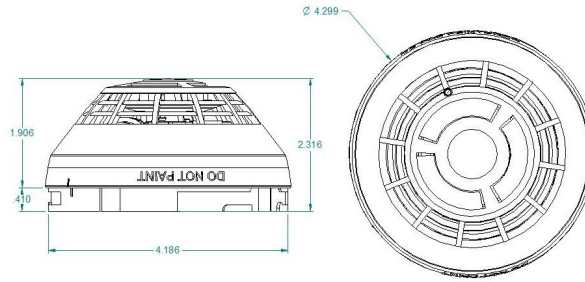

Specifications

Operating voltage	15.20 to 19.95 VDC
Normal operating current	51 μ A
Alarm current	68 μ A
Smoke Sensitivity Range	UL/ULC: 0.53 to 3.94 %/ft. (1.7 to 12.35 %/m) obscuration
Vibration level	10 to 35 Hz, with an amplitude of 0.01 in.
Air velocity	0 to 4,000 ft./min (0 to 20 m/s)
Wall mounting	12 in. (305 mm) max. from ceiling
Compatible bases	See Ordering Information
Compatible detector testers	Testifire 1000, Testifire 2000
Operating environment	32 to 120°F (0 to 49°C), 0 to 93% RH, noncondensing
Construction	High Impact Engineering Polymer, White
Storage temperature	-4 to 140°F (-20 to 60°C)
Environmental compensation	Automatic
Agency Listings	CAN/ULC-S529, UL 268, UL 268A

Ordering Information

Catalog Number	Description	Ship Wt. lbs (kg)
KIR-PD	Intelligent Optical Smoke Detector	0.4 (0.16)

Accessories		
KI-SB	Detector Mounting Base - Standard	
KI-SB4	4-inch Detector Mounting Base c/w Trim Skirt	
KI-RB	Detector Mounting Base w/Relay	
KI-RB4	4-inch Detector Mounting Base w/Relay, c/w Trim Skirt	0.2 (.09)
KI-IB	Detector Mounting Base w/Fault Isolator	
KI-IB4	4-inch Detector Mounting Base w/ Fault Isolator, c/w Trim Skirt	
GSA-LED	Remote Alarm LED (not for EN54 applications)	
KI-ABST	Audible (Sounder) Base for Fire Detectors	0.3 (0.15)
KI-ABLT	Low Frequency Audible (Sounder) Base for Fire Detectors	0.3 (0.15)
KI-DMP	Detector Mounting Plate	3.0 (1.4)
KI-RTA	Detector Removal Tool	
KI-VA	Detector Cleaning Tool	